

PRODOTTO

**VASCA PER LO STOCCAGGIO DI 2
CISTERNETTE DA 1000L (SERIE ECO)**

CODICE

410 000 516

CARATTERISTICHE DEL PRODOTTO
Caratteristiche Contenitore

| | |
|-------------------------|----------------------------------|
| MATERIALE | 100% polietilene a media densità |
| DIMENSIONI (mm) | 2500 x 1300 x (h) 530 |
| DIMENSIONI GRIGLIA (mm) | 1200 x 2400 |
| VOLUME DI RACCOLTA | 1050 L |
| PORTATA | 3900 kg |

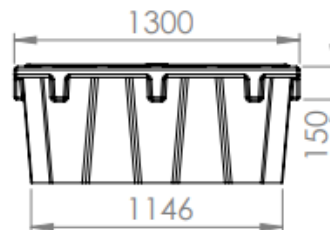
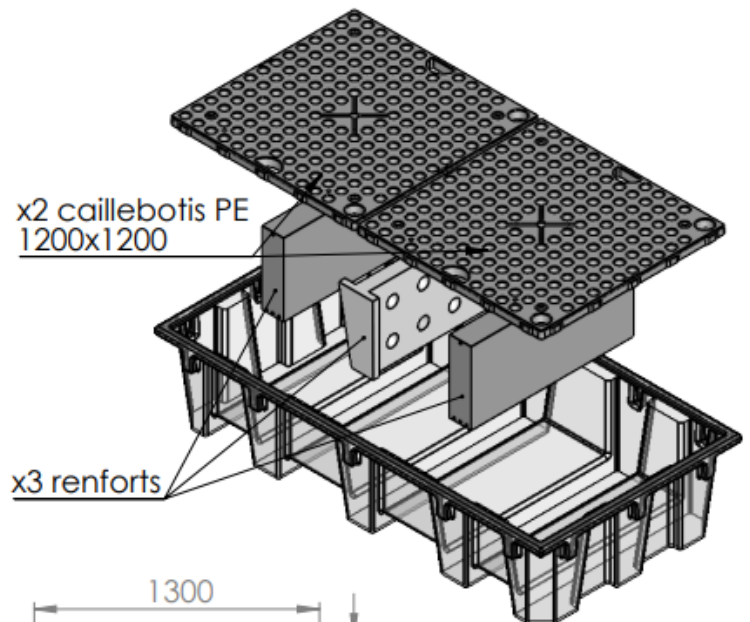
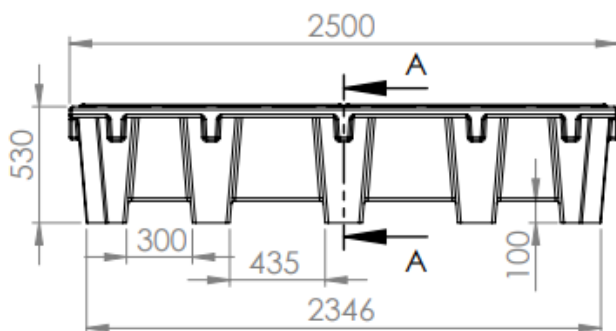
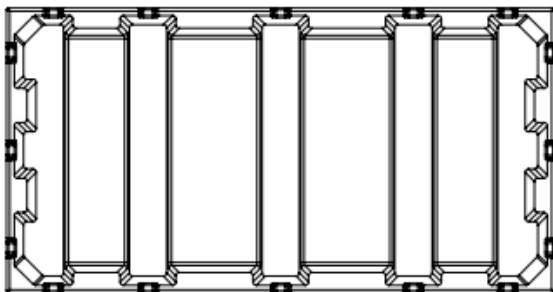
Dimensioni

AIRBANK srl

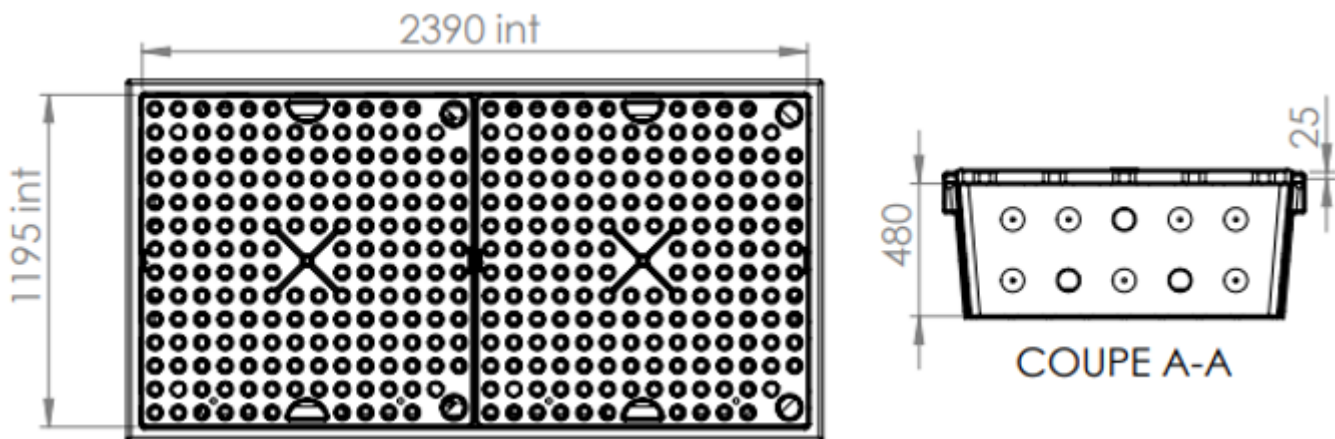
 Via Luigi Bay - 29121 PIACENZA • Tel. +39 0523 763134 • fax +39 0523 76314
 info@airbank.it • www.airbank.it • P.Iva / C.F. 01536470337



NOTE
