

PRODOTTO **VASCA PER LO STOCCAGGIO DI 1**
CISTERNETTA DA 1000L (SERIE ECO)

CODICE 410 000 514



CARATTERISTICHE DEL PRODOTTO

Caratteristiche Contenitore

MATERIALE	100% polietilene
DIMENSIONI (mm)	1380 x 1280 x (h) 1000
DIMENSIONI GRIGLIA (mm)	1300 x 1200
VOLUME DI RACCOLTA	1100 litri.
PORTATA	1500 kg

Dimensioni

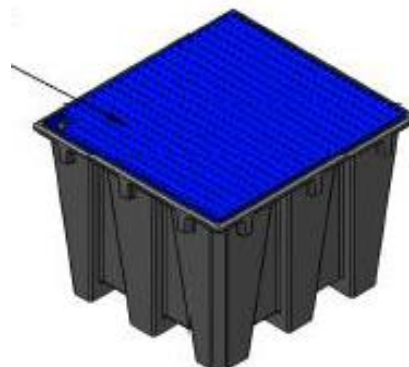
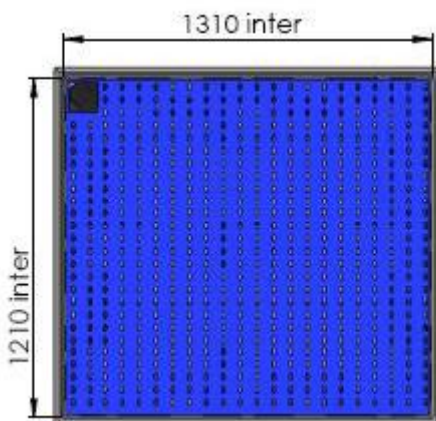
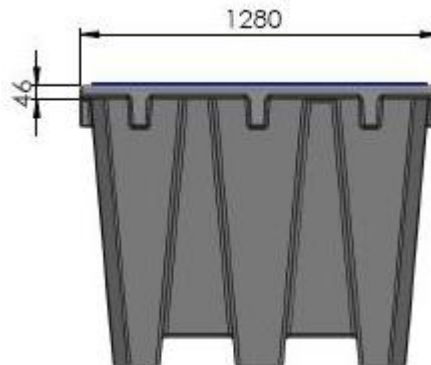
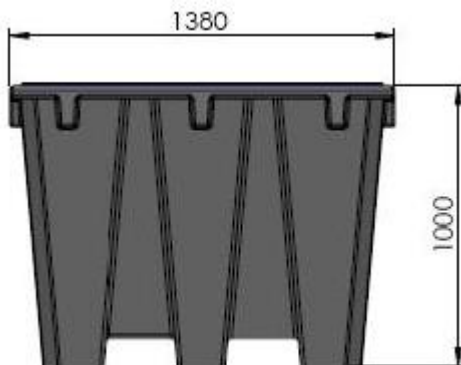

NOTE

AIRBANK srl

Via Luigi Bay - 29121 PIACENZA • Tel. +39 0523 763134 • fax +39 0523 76314
info@airbank.it • www.airbank.it • P.Iva / C.F. 01536470337